



## The Influence of Social Media Influencers on Consumer Decision-Making: A Comprehensive SEM Analysis

**Noman Ahsan**

PhD Scholar, Department of Public Administration, University of Karachi-Pakistan

[nauman.nomi.ahsan@gmail.com](mailto:nauman.nomi.ahsan@gmail.com)

**Sobia Jamil (Corresponding Author)**

Lecturer, Department of Business Administration, Jinnah University for Women, Karachi - Pakistan

[sobiajamil901@gmail.com](mailto:sobiajamil901@gmail.com)

0000-0002-9760-1034

**Madiha Rais**

Lecturer, Department of Business Administration, Jinnah University for Women, Karachi - Pakistan

[madiharais2016@gmail.com](mailto:madiharais2016@gmail.com)

### Abstract

*In recent times, social media influencers and their marketing campaigns have gained significant popularity and attention. The aim of this study is to identify the extent to which social media influencers impact consumer decision-making and buying behaviors. The paper examines influencer marketing as a form of electronic word-of-mouth (eWOM) and how it affects the consumer purchase journey. Framework is developed using existing literature on topics like consumer decision-making, eWOM, opinion leadership, source credibility, and digital interaction. The methodology utilizes a deductive research approach with a cross-sectional quantitative survey. The target population comprises consumers in Karachi who regularly use social media. The study uses Structural equation modeling (SEM) analysis to identify the relationship between social media word mouth, quality of information, Digital interaction, Digital Attractiveness, and Digital interaction on consumer decision-making with the mediation effect of opinion leaders. Convenience sampling is employed to collect data from over 150 respondents. The results provide empirical evidence that opinion leadership and source credibility significantly influence consumer decision-making when it comes to influencer marketing. This implies that the personality and perceived trustworthiness of the influencer matter more than their attractiveness or expertise. However, digital expertise is not found to have a positive effect. Overall, the findings highlight the need for brands to partner with credible influencers who can leverage their leadership to steer audience opinions and purchases. Future research can build on this by investigating negative eWOM, commercialism, and manipulating tactics used by influencers. The paper contributes to the growing research on social media marketing and how online opinion leaders shape consumer behaviors.*

**KeyWords:** *Social media of Mouth, Digital Interaction, Digital Interactions, Digital Attractiveness, Opinion leadership, Purchase Decisions, Social Media Marketing,*



## **Introduction**

In today's digital age, social media has become deeply embedded in people's daily lives. Platforms like Instagram, Facebook and YouTube provide users with endless content created by influential figures known as social media influencers. These influencers have cultivated large followings based on their expertise, attractiveness or just general likeability. The concept of "social proof" holds that individuals are affected by the actions, purchases, and recommendations of others. People may now more easily get and share information about goods, services, and brands thanks to social media (Alsokkar, 2022). This gives more information to other prospective buyers, enabling them to decide for themselves whether or not to buy a product. Customers have the ideal forum to voice their thoughts about goods and services thanks to social media. Brands and companies are increasingly leveraging influencers as part of their marketing strategy, paying them to promote products to their many followers. This new form of marketing, known as influencer marketing, is essentially a type of electronic word-of-mouth (eWOM) communication between influencers and consumers. It has rapidly grown in popularity as consumers increasingly look to social media personalities for opinions and recommendations before making purchases (Iouro & Patricia, 2020). Consumers perceive online reviews and social media interactions as more reliable than conventional advertisements when making decisions (Ghasemaghaei & Hassanein, 2013; Hamed et al., 2022). The annual rise in social media use and the steady maintenance of high user counts on well-known platforms—statista data (2022a) shows that social media penetration is 90.2%—are scarcely unexpected. The age groups most likely to utilize social networking sites are Gen Z and younger people. 25 to 34-year-olds make up one-fourth of all social media users; 12.8% of women and 12.4% of men fall into this age group. Ninety percent of people in this age group in 2023 have a profile on an online social networking site. According to a March 2023 survey, 73% of participants used social media on a regular basis, while just 3% said they never used it. Despite all of its applications, social media is often used as a news source. But newcomers to the market have created fads and identified niches in which to compete with established social media giants for users' attention (Khan et al., 2022). Opinion leaders who demonstrate expertise, attractiveness and credibility tend to be persuasive and trusted by followers (Millwood, 2021). Thus, influencers who embody these traits could leverage their leadership to shape audience attitudes and choices.

The study puts forward the following research objectives:

- To examine the relationship between social media word-of-mouth from influencers and consumer decision making.
- To determine the role of opinion leadership as a driver of influencer credibility and consumer decision making.
- To investigate the effects through equation modeling analysis of influencer attractiveness, expertise and digital interaction on consumer decision mark

### Significance of the study

These objectives will be achieved by conducting a quantitative study among social media users in Karachi, the largest metropolitan area in Pakistan. The research model incorporates key variables identified from existing literature on social media marketing, eWOM and consumer behavior. Statistical analysis of survey data will be used to test hypothesized relationships between the variables. The findings are intended to provide clarity on the consumer psychology behind influencer marketing effectiveness. They will also inform influencer-brand partnerships and responsible promotion practices.

### Literature Review

Figure 1  
Theoretical Framework

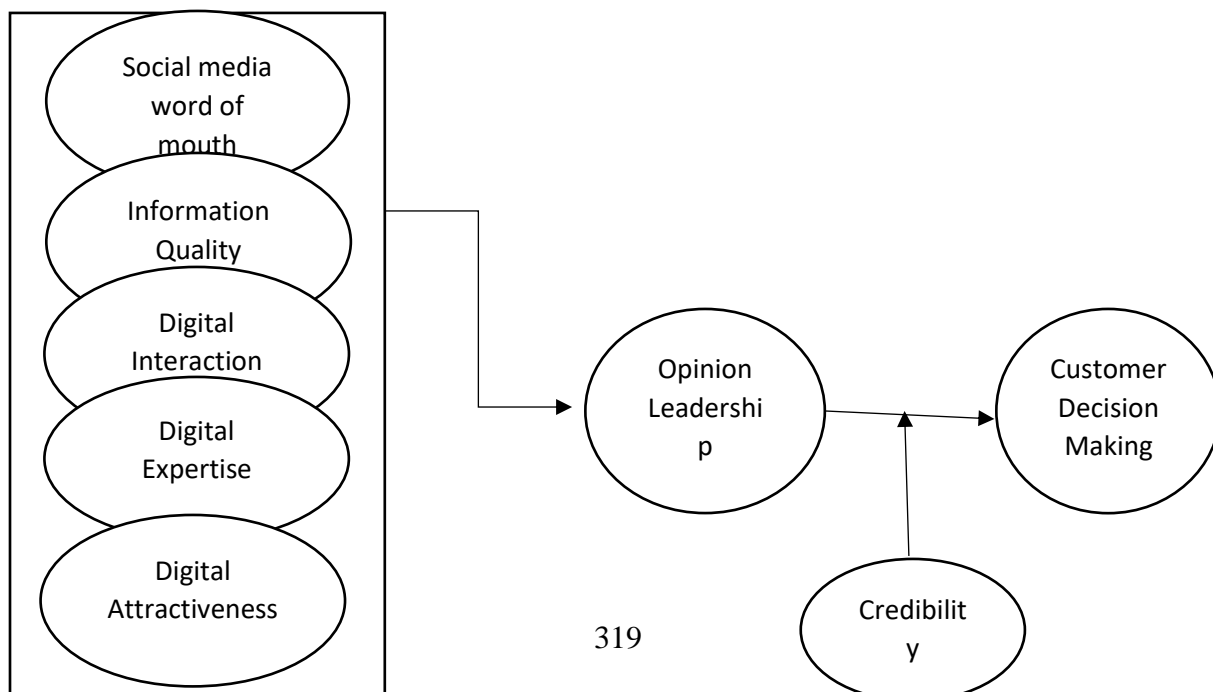



### **Theoretical Exposition**

The theory of decision making provides support for this study work. Oskar Morgenstern and Nicholas Bernoulli conducted research on and a review of the decision-making theory (1978). Decision-making theory is a theory of how balanced individuals should behave under risk and uncertainty. This theory was predicated on the cognitive process of anticipating the results of decisions. Researchers have also shown that marketing initiatives have a significant psychological impact on consumers, which influences their decision-making. This decision theory is normative rather than descriptive. That is, it is a theory of how individuals should make decisions rather than how they do make decisions. Presence of social media influencers are now making the decision-making process easy. Decision making theory support people's choices through a group of concepts, principles, tools and techniques influence the respective decision such as purchasing decision. They allow decision makers to select the best alternatives among a set of different alternatives. Similarly, there are lots of influencers promoting products but it depends on influencer's expertise, attraction, interaction, credibility and opinion leadership. That how these characteristics attract customers towards them (Zak & Hasprova, 2020). According to decision-making theory, influencers significantly affect the information processing and decision-making phases by influencing how information is interpreted, analyzed, and used. Their capacity to impart knowledge, provide options, and set an example of conduct is essential in helping their followers make decisions. That's why this theory supports this study because social media influencers have the power of authority to change the decision of customers.

### **Consumer Decision Making**

The process by which customers become aware of, identify, and get sufficient information to address their requirements is known as the "consumer decision making process." Following this, customers assess their options, decide what to buy, and estimate the cost of their purchase. Millwood (2021) Consumer decision-making process is somehow very important to be understood because it leads you to expect the needs of consumers which makes it easy for you to plot marketing or sales strategies in return, based on those needs or demands. If we talk about present era, we are living in a technological world. Technology and social media is not only affecting and impacting the consumer decision making process but it is playing a vital role in every aspect of life. Social media effects consumer decision making as mostly all the businesses



are doing digital marketing and are present digitally which helps them in guiding and help consumers in decision making. Businesses try to grab customers through their unique advertisements mostly business try to touch consumers' sentiments through emotional advertisement.

Social media word-of-mouth have an ability to spread awareness about any brand through references and recommendations, social media word of mouth can affect consumer purchase intention in a positive or negative both ways by influencing the consumers purchase decision makings. (sa'ait & Kanyan, 2016; Zaheer et al., 2023). Information quality is mainly defined as the quality of the content share by the individuals and here individual refer to social media influencers, it should be accurate and complete. Therefore, it is highly relied upon decision making. Quality information provided by the social media influencers is useful and plays a beneficial role in customer decision making. Digital interaction is all about the communication with and access to any services through a systems and devices. It means that how social media influencers are interacting and communicating with customers. It has completely changed the perspective of consumers towards online buying and purchasing, it also inspire and encourage the consumers to shift themselves up to digital marketing than outdated hectic marketing. Digital expertise is called as that ability which helps to discover, evaluate, practice, share, and generate content using digital means or devices also. The influence of digital transformation extends beyond businesses and marketing to include consumers. The methods in which customers communicate, get, and exchange information about goods and services, as well as how they acquire and use them, are all significantly altered by the process of digitalization (Bhagat & Ahire, 2021).

## **Hypothesis Development**

### **Social Media Word of Mouth and Consumer Decision Making**

With time, consumers are using online resources (such as blogs and social media) to learn more about the organizations that provide the goods and services they use, as well as to voice their thoughts about the goods and services they use (Gupta and Harris, 2010; Lee et al., 2011). Social media word of mouth is referred as the positive or negative feedback of any good product or service on social media platform given by social media influencers. These instruments are



profoundly altering daily existence and the dynamic between consumers and companies (Lee et al., 2011).

Word of mouth can be positive and negative it depends upon consumers mind, their satisfaction and experience. Consumers yields positive word of mouth when they go through with favorable experience and consumers response negatively when they go through with unfavorable circumstances (Buttle, 1998). Social media websites have effectively transformed users from being passive viewers into active contributors. Unintentional generation of EWOM is easy, particularly when customers express their preferences via network interactions with companies that are associated with postings by like, commenting, and publishing (Alocer, 2017). Social media websites have been effective in converting users from being passive viewers to becoming involved participants. EWOM may be produced quickly, particularly when customers express their preferences via network interactions with companies by publishing, like, and commenting on postings (leong et al., 2021).

*H1; Social media word of mouth has a positive effect on consumer decision making.*

### **Information Quality and Consumer Decision Making**

Information quantity and quality are considered to be two of the most important foundations that influence decision quality in the information processing literature (Keller & Staelin, 1987; Paul & Nazareth, 2010). Information quality influences consumer decision making because it offers reliable and accurate information. With such knowledge, consumers can make any choice with ease. Therefore, the amount and quality of the information may be used to quantify the hypothesized involution in this work. Information quality is defined as the usefulness of the available to required information in assisting a decision maker in making better decisions based on the information they obtained, according to Gao, Zhang, Wang, and Ba (2010). (Hassan et al., 2019). When there is no chance for online shoppers to physically engage with things, information quality (IQ) is essential in helping them make judgments about what to buy (Wixom & Todd, 2005; Kim & Lennon, 2008). As a result, one of the key factors contributing to online customer happiness has been identified as information quality (Ghasemaghaei & Hassanein, 2013).

*H2; Information quality shows a significant effect on consumer decision making.*

### **Digital Interaction and Consumer Decision Making**

The Zaheer et al. (2023) approach emphasizes how digital technologies affect consumer behavior. The author claims that these technologies have lessened the inconsistencies in



information that now exist between the client and the business. These days, anybody may visit a business' website to learn more about its offerings. The development of digital channels has improved communication between businesses and customers. Channels like email, social media, and search engines have helped businesses improve their value proposition, which has helped them attract the right clients and raise the value of the customer experience (Jamil et al., 2023). The well-known study by Edelman and Singer, which reveals that customer behavior altered with the introduction of online technology, is often used in research on consumer behavior. They give information on the company's news, outline the services offered, and enable ongoing communication between businesses and customers (Pires et al., 2022).

*H3; Digital interaction has a positive effect towards consumer decision making.*

### **Digital Expertise and Consumer Decision Making**

The capacity to locate, assess, utilize, exchange, and create material utilizing digital platforms and devices, such computers and smartphones, is known as digital expertise. The knowledge and abilities people need to utilize information and communication technology in the best possible way. Digital literacy, data management, teamwork, communication, content creation, security, and the capacity to resolve issues in virtual settings are all included in this. "Digital shopping formats that businesses use to offer online shopping opportunities to consumers" is what (Jamil et al., 2023) define as digital channels. Instead of focusing just on the conventional sales process, businesses aim to create an emotional experience when a customer browses a digital channel. Digital channels aim to engage customers in conversation throughout the purchasing process, elicit feelings and mindsets that are shared by companies and consumers to build lasting relationships, and encourage brand loyalty in addition to selling (Azzahra et al., 2024).

*H4; Digital expertise significantly affect the consumer decision making.*

### **Digital Attractiveness and Consumer Decision Making**

The concept of attractiveness serves as the foundation for social relationships and is crucial in forging personal connections. In society, one's beauty might be seen as capital. Numerous studies have looked at how crucial it is for endorsers or influencers to be beautiful, and how much of an impact this has on consumers' decision-making. The attractive they will seem digitally the more they will grab customers (Kim & Park, 2023). This research also has an objective that how



digital attractiveness of social media influencers effects consumer decision making. In order to obtain the results, it was planned to use quantitative approach, by distributing an online survey to members of social networks. It is undeniable that social media, particularly Instagram, where the majority of users follow influencers, plays a significant role in our everyday lives. Similarly, the primary goal of the study was to demonstrate that influencers' digital attractiveness affects their followers' propensity to make purchases; this effect is more for women than for males(Khan et al., 2022). Additionally, it has been shown that positive eWOM influences customers more than negative ones since most people are persuaded to purchase a good or sign up for a service, but very few are persuaded not to because someone warned them it wouldn't be worthwhile (Iouo & Patricia, 2020).

*H5; Digital attractiveness of influencers positively effect on consumer decision making.*

### **Opinion Leadership and Consumer Decision Making**

Here, social media influencers are referred to as leaders. those who try to persuade customers and assist them in making decisions by offering their own opinions. Social networking websites like Instagram, LinkedIn, Facebook, and Twitter have had a significant impact on customers' decision-making in recent years. Influencers are persuasive and thought leaders because of their unique personal attributes, such as extraversion and beauty. Lazarsfield is credited with creating the idea of opinion leadership. Opinion leadership has often been characterized as one of the main ways that people may frequently and in a desirable manner influence attitudes or actions. Opinion leaders in marketing are customers who have an impact on other customers' attitudes, actions, and decisions. In fact, opinion leadership happens when people attempt to influence other customers' purchase decisions to favor certain product categories (Jamil et al., 2024; jegham & Bouzaabia, 2022).

The attributes of personal participation, acquaintance with and understanding of a product, and individualism in the public are defined as opinion leadership traits. Opinion leadership encompasses both technical and societal transformations (chai et al., 2022). Opinion leaders' views have an impact on consumers' choices and habits. The two prerequisites for an opinion leader to be able to influence others are having expertise of a certain topic or product and wanting to interact with others. Opinion leaders get a lot of attention from businesses hoping to use them to promote the benefits of their goods to others due to their ability to influence others'





purchasing choices. Opinion leaders are probably eager to share what they know, therefore they could choose a platform like blogs or online forums that facilitates more extensive contact.

*H6; Opinion of influencers significantly effect on consumer decision making.*

### **Credibility and Consumer Decision Making**

The link between decision-making and opinion leadership is moderated by credibility. The degree to which someone is presumed to possess relevant competence in a certain subject and can be relied upon to offer an unbiased view on the subject is referred to as their credibility. Establishing credibility is crucial for fostering trust and boosting power (Jegham & Bouzaabia, 2022). When a customer finds a product review reputable, they are more likely to believe the source, follow the advice, and utilize it when making judgments about what to buy. As a result, social network users were more cautious and believed that people's trustworthiness was the most crucial component when it came to accepting advice or believing anything they read online. When consumers see social media influencers as reliable, their likelihood of purchasing the goods increases. Credibility increases the likelihood that consumers will buy things advertised online. Effective decision making is a consequence of social media influencers' high reputation.

*H7; Credibility of influencers has a significant influence on consumer decision making.*

### **Credibility Moderate the relationship between Opinion Leadership and Consumer Decision Making**

Measuring credibility by appearance, dependability, and knowledge helps one to better understand how opinion leaders could affect customer buy intentions. Influencers that create parasocial links with their audience have especially powerful this impact (Yuan & Lou, 2020). Furthermore, trust and experience—two fundamental elements of credibility—much improve the impact of opinion leaders in highly involved transactions. For difficult purchasing choices including real estate and financial items, consumers depend increasingly on reputable opinion leaders (Hsiao et al., 2024). Online environments affect customer buying choices by means of the legitimacy of opinion leaders, along with the apparent quality and volume of evaluations. Greater credibility results in more confidence in the reviews, therefore improving their influence on customer decisions (Ren et al., 2024). Consumer decision-making in word-of-mouth communications is much influenced by reliable sources. Higher effect on customer choices



results from trust in the opinion leader improving the perceived value and dependability of the information exchanged (Khan et al., 2022).

*H8; Credibility moderately influencers has a significant influence on opinion leader and consumer decision making.*

## **Methodology**

### **Research Approach**

The study based on deductive approach because it is discussing about the impact of social media influencers on consumer decision making which is an existing theory and here we are aiming to expand this theory. Deductive approach using the test of relation among the variables such as Social media word of mouth, digital attractiveness, digital interaction, quality of information effect on consumer decision making. Furthermore, study also test mediating effects of opinion leader on consumer decision making.

### **Data Collection**

A population is a whole arrangement of people chosen for a research (Saunders, 2009). The target population for this study consisted of Karachi residents who are used to making purchases from various online retailers and platforms and who are knowledgeable about social media influencers and how they affect consumers' perceptions and buying choices. In the deductive process, a theory is developed based on an existing hypothesis, which is then tested for veracity and modified in light of new data. The deductive method is used in this study's analysis to produce hypotheses that are then evaluated for confirmation by abusing preexisting theory. Abbas et al. (2023), Stutely (2003) suggests that a minimum of thirty sample sizes be used for statistical analysis. Saunders provides the study's benchmarks when constructing the sample size. Additionally, Saunders (2009) recommends 150 samples, 30 of which for each variable.

### **Instrument**

The questionnaire is the “efficient data collection mechanism when researcher knows exactly what is required and how to measure the variables of interest” (Sekarssan, 1992). Changes in independent variables caused by changes in dependent variables. In order to test Social media Word Of Mouth, questions are developed by (Pires, 2022), Digital Interaction was examined by using the tactics of (Santos, 2022), Digital Expertise was assessed by the examination of (De Brito, 2022), the variable Digitally Attractiveness was measured using the contents developed by (Marques, 2022), Information Quality tested by the ideas validated by (AL-Sous, 2022), In



order to inquire about Opinion Leadership this study uses the scale developed by (Almajali, 2022), to find out the Credibility of social media influencers impacting upon consumer decision making study used the tactics prepared by (Alsokkar, 2022) and at last the final variable Customer Decision Making was inquired by the (Ao & Bansal, 2023).

### **Data Analysis**

Partial least square equation modeling (PLS-SEM) was used in the current work to analyze the data using Smart PLS (3), a statistical tool. Based on the features of the data/sample and the moderation and mediation analysis, this analytical strategy was chosen. In research on marketing, human resource management, and other relevant topics, this strategy has also gained a great deal of recognition (Bradburn et al., 2003). According to Hair et al. (2013), PLS-SEM may be used to predict the dependent variables' outcomes. Similarly, (Moon & Russell, 2008) suggested that this approach establishes the link between variables and is appropriate for forecasting a set of equations collectively for the suggested study model. This research does rigorous analysis in the management sciences sector using PLS-SEM, a confirmed reporting technique. SEM is a flexible, second-generation data analysis technique that looks at additive and linear casual interactions that have been theoretically created. It enables academics to look at how different constructions relate to one another. SEM is thought to be the most effective method for evaluating both direct and indirect routes since it examines hidden structures that are hard to see and difficult to study. The links between independent and dependent variables as well as between latent constructs and their observed key points are examined in structural equation modeling (SEM), which comprises of inner and outer model analysis. Variance analysis is the main emphasis of PLS and may be performed using Smart PLS. As a result, the latest research chose this strategy.

### **Results**

#### **Common Biased Method**

The given research, verified the common method bias of collected data, it can be happened due to uniformity credibility and opinion leadership. Following (Podsakoff & Organ, 1986) the Harman's 1-factor test was conducted with the multiple construct in current research model including social media word of mouth, digital interaction, digital expertise, digital attractiveness, opinion leadership, credibility, information quality and customer decision making so the sample



which is used in this study has no significant concern with regard to common method bias (Saeed & Shafique, 2020). As shown in Table 1.

Table 1  
 Common Bias Method

Constructs	VIF
Social media Word Of Mouth 1 (SWOM1)	
Social media Word Of Mouth 2 (SWOM2)	2.454
Digital Interaction 1 (DI1)	1.625
Digital Interaction 2 (DI2)	2.591
Digital Expertise 1 (DE1)	1.635
Digital Expertise 2 (DE2)	2.238
Digital Attractiveness 1 (DA1)	1.973
Digital Attractiveness 2 (DA2)	1.929
Information Quality 1 (IQ1)	1.514
Information Quality 2 (IQ2)	2.162
Opinion Leadership 1 (OL1)	1.541
Opinion Leadership 2 (OL2)	1.541
Credibility 1 (C1)	1.307
Credibility 2 (C2)	1.307
Customer Decision Making 1 (CDM1)	1.259
Customer Decision Making 2 (CDM2)	1.259
C x OL	1.000

Table 1 summarized the values of VIF. VIF is conventional and perhaps the important one for analyzing common method bias. The VIF values of SWOM2 are 2.454. The VIF value of DI1 and DI2 are 1.625 and 2.591. The VIF values of DE1 and DE2 are 1.635 and 2.238. The VIF values of DA1 and DA2 are 1.973 and 1.929. The VIF values of IQ1 and IQ2 are 1.514 and 2.162. The VIF values of OL1 and OL2 are 1.541 and 1.541. The VIF values of C1 and C2 are 1.307 and 1.307. The VIF values of CDM1 and CDM2 are 1.259 and 1.259. The VIF values of C x OL are 1.000.

### Confirmatory Analysis (CFA)

#### *Internal consistency*

The current study has determined the internal consistency of the constructs through Cronbach's values. Study have presented the results in Table 2 Cronbach's alpha values were above the



threshold of 0.70 set by (Gadermann et al., 2012): SWOM ( $\alpha = 0.886$ ), OL ( $\alpha = 0.744$ ), C ( $\alpha = 0.653$ ) and CDM ( $\alpha = 0.624$ ).

### **Convergent validity**

Table 2 summarizes the result of composite reliability (CR) and average variance extracted (AVE). CR values were above the threshold of 0.7 (Hair et al., 2017): SWOM (CR = 0.908), OL (CR = 0.886), C (CR = 0.852) and CDM (CR = 0.841). The AVE values were also above the threshold of 0.50 (Chin, 2010): SWOM (AVE = 0.526), OL (AVE = 0.795), C (AVE = 0.742) and CDM (AVE = 0.726). Factor Loadings were significant, and t-values were above the threshold value of 0.50 (Hair et al., 2017). The values of CR > 0.7 (Hair et al., 2017) and AVE > 0.5 (Chin, 2010) were above the threshold values and fulfilled the standard requirements for validity (Schuberth et al., 2018).

### **Outer Loading**

Table 2 shows that, in comparison to other constructs, individual items of each item are loaded higher in their relevant construct since their cross-loading difference exceeds the suggested threshold of 0.1 suggested by (Gefen & Straub, 2005), it also confirms the discriminant validity.

Table 2  
Confirmatory Analysis

Construct Name	Items	Outer loadings	Cronbach's Alpha	CR	AVE
Social Media Word Of Mouth	SWOM1		0.886	0.908	0.526
	SWOM2	0.812			
Digital Interaction	DI1	0.631	0.876	0.912	0.564
	DI2	0.800			
Digital Expertise	DE1	0.692	0.761	0.981	0.452
	DE2	0.781			
Digital Attractiveness	DA1	0.685	0.824	0.876	0.467
	DA2	0.683			
Information Quality	IQ1	0.645	0.834	0.849	0.567
	IQ2	0.774			
Opinion Leadership	OL1	0.911	0.744	0.886	0.795
	OL2	0.872			
Credibility	C1	0.870	0.653	0.852	0.742
	C2	0.853			



Customer Decision Making	CDM1	0.874	0.624	0.841	0.726
	CDM2	0.830			

Above Table 4 shows the results of the reliability and validity testing of the measurement scales.

### Discriminant Validity

The Fornell-Larcker criteria is then used to evaluate discriminant validity. The development of discriminant validity guides the concept's uniqueness and captures the phenomena that is not understood by others. According to Yusuf and Busalim (2018), the correlations between the constructs were not found to be larger than the square root of the variance retrieved between each pair of components. Table 3 demonstrates that the constructs are distinct and distinctive since the square root of AVE is greater than the correlation values. Table 3 Heterotrait-Monotrait ratios (HTMT)

Table 3  
 Heterotrait-Monotrait ratios

	Social Media Word Of Mouth	Information Quality	Digital Interaction	Digital Expertise	Digital Attractiveness	Opinion Leadership	Creditability	Customer Decision Making
Social Media Word Of Mouth	0.978							
Information Quality	0.957	0.987						
Digital Interaction	0.675	0.876	0.856					
Digital Expertise	0.874	0.675	0.563	0.845				
Digital Attractiveness	0.567	0.731	0.763	0.765	0.976			
Opinion Leadership	0.632	0.543	0.832	0.754	0.765	0.976		
Creditability	0.784	0.621	0.547	0.632	0.831	0.836	0.762	
Customer Decision Making	0.654	0.912	0.675	0.543	0.876	0.543	0.631	0.908

Heterotrait-Monotrait ratio (HTMT) is the modern standard for assessing and computing the discriminate validity. According to Table 5 Heterotrait-Monotrait ratio (HTMT) values of these construct was under the recommended values 0.9 (Henseler et al., 2015) which thereby verify that the discriminate validity is established.

### Structural Model

The study has created a structural model based on bootstrapping of 5,000 subsets. The structural model is presented and the model and hypotheses' outcomes are in subsequent sections.

Figure 2  
Structural Model

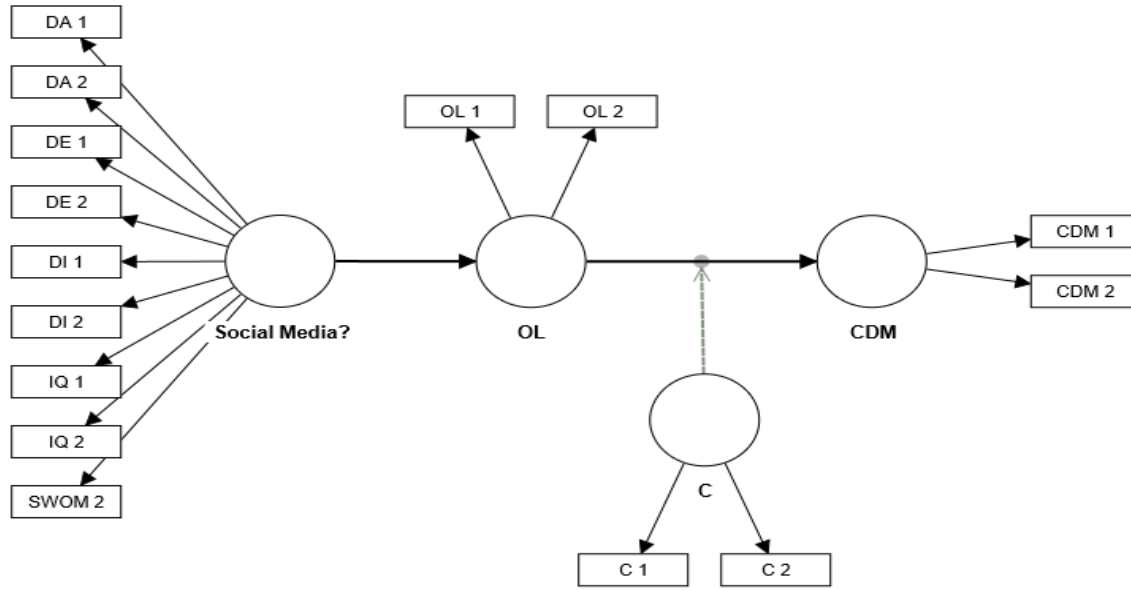

### Measurement Model

Measurement models refer to the implicit or explicit models that relate the latent variable to its indicators. Figure 3 shows measurement model.

Figure 3  
Measurement Model

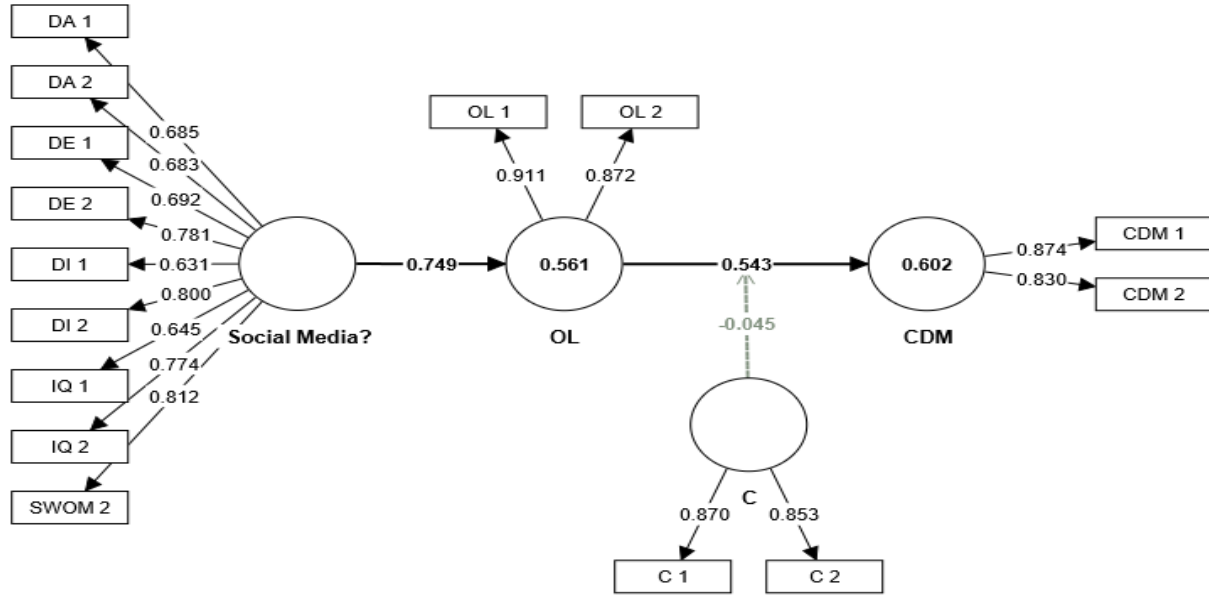

### Predictability of the Model

This study has determined the likelihood of the model based on R square values. The adjusted r square values are greater than 0.10, telling that the model has acceptable predictive power. As shown in table 4

Table 4  
 Predictivity of the Model

	R-Square	R-Square Adjusted
Customer Decision Making	0.602	0.599
Opinion Leadership	0.561	0.599

### Hypothesis Results

Table 9 shows the hypotheses testing in which indicates that five hypotheses out of eight are found to be supportive. Social media Of Mouth (H1) has a significant determinant influence on Customer Decision Making with t-statistics 5.894 (p=0.002). information quality (H2) has a significant impact on Customer Decision Making with t-statistics 12.702 (p=0.001). Credibility significantly moderates between Opinion Leadership and Customer Decision Making with t-value 1.806 (p= 0.032). Thus H1, H2, H3, H5 and H8 were supported whereas H4, H6 and H7 were not supported.

Table 5





## Hypothesis testing

Hypothesis	Structural relation	Std. deviation (STDEV)	T- Values	Beta	P- Values	Result
H1	<i>Social media word of mouth -----&gt; consumer decision making.</i>	0.048	5.894	0.076	0.002	Accept
H2	<i>Information quality----&gt; consumer decision making.</i>	0.043	2.702	-0.034	0.001	Accept
H3	<i>Digital interaction-----&gt; consumer decision making.</i>	0.029	6.269	0.065	0.031	Accept
H4	<i>Digital expertise ----&gt; consumer decision making</i>	0.025	1.806	0.971	0.324	Reject
H5	<i>Digital attractiveness ----&gt; consumer decision making.</i>	0.029	7.321	0.063	0.043	Accept
H6	<i>Opinion of influencers -----&gt; consumer decision making.</i>	0.029	6.476	-1.056	0.502	Reject
H7	<i>Credibility of influencers ---&gt; consumer decision making</i>	0.029	2.567	0.867	0.413	Reject
H8	<i>Opinion of influencers*Creditability ----&gt; consumer decision making</i>	0.045	4.436	-0.342	0.032	Accept

## Discussion and Conclusion

### Discussion

Five of the eight hypotheses put out and examined by the current research are supported by the findings. In the part that follows, the study's findings and their applicability to earlier research are covered. Hypotheses (H1) states that Social media word of mouth significantly influences on Consumer decision making, with the effect size ( $\beta=-0.034$ )<sup>2</sup>. The current results have been validated with the results of previous studies. Influencers have been most frequently used for marketing and sales purposes.(Chen et al., 2023). From past few years social media has been a center of attention for buyers in order to grab opinions from influencers and to make purchase decisions. Social media influencers are also significant because of their capacity to disseminate sponsored messages across their networks by embedding the messages in material that appeals to their followers (Chen et al., 2023). The research goals outlined in the first section were achieved



via this testing, demonstrating that social media influencers have a favorable effect on customer decision-making. Hypotheses (H2) states that credibility significantly influences information quality on consumer decision making, with the effect size ( $\beta=-0.034$ )<sup>2</sup>. The current results have been validated with the results of previous studies. A information quality is a human ability, which can redirect and guide human to make any decision related to purchasing but sometimes social media influencers use this ability for their own benefits and encourage people to make wrong decisions. A more comprehensive range of approaches is developed and used by opinion leaders to uplift consumers to make a decision which is more valuable for their own sake, rather than for consumers. (Jain et al., 2023). This research posited that the quality of information has a crucial role in shaping consumers' decision-making process.

Hypotheses (H3) states that Digital interaction has a positive effect towards consumer decision making. with the effect size ( $\beta=-0.065$ )<sup>2</sup>. The emergence of digital channels has enhanced communication between businesses and customers. Channels such as social media, search engines, and email have assisted businesses in refining their value proposition, which has allowed them to draw in the target market and increase the value associated with the customer experience (Pires et al., 2022).. Hypotheses (H4) states that Digital expertise has not significantly affect the consumer decision making with the effect size ( $\beta=-0.971$ )<sup>2</sup>. Studies show that in high-information environments, customer knowledge has little impact on buying choices. Although experts usually perform better in high-information contexts, this does not necessarily translate to appreciable effects on their general decision-making process (Lavuri & Gopi, 2024). Often, the impact of digital marketing methods on customer choices dominates that of individual digital knowledge. For example, regardless of the customer's degree of digital knowledge, digital marketing significantly shapes consumer choices by means of tailored advertising (Rahmani & Sarma, 2023).

Hypotheses (H5) states that Digital attractiveness of influencers positively effect on consumer decision making with the effect size ( $\beta=-0.063$ )<sup>2</sup>. Consumer purchase intentions are improved by the appealing qualities of influencers—physical beauty as well as interesting personalities. Moreover very important for this impact are trustworthiness, genuineness, and attitude homophily (Azzahra et al., 2024; Jamil et al., 2024).



Hypotheses (H6) states that Opinion leadership has not significantly influences on Consumer Decision Making with the effect size ( $\beta = -1.506$ )<sup>2</sup>. The current results have been validated with the results of previous studies. Consumers are increasingly using social media to gather information before making purchasing choices. According to previous studies, influencers have not a considerable effect on customer purchasing behaviors via product testing evaluations and recommendations. According to the firm's perspective, influencer marketing is a practical approach for customer appeal and attainment to encourage them to purchase. According to research, around 60% of customers consult social media postings or vlogs before buying a product (Khan et al., 2021). Hypotheses (H7) state that credibility has not a significant influence on consumer decision making with the effect size ( $\beta = 0.867$ )<sup>2</sup>. The outcomes of earlier research have been used to validate the present findings. According to some research, consumers' perceptions and interpretations of stimuli are influenced by the information source's trustworthiness. It is thought that credibility consists of two fundamental aspects: competence and reliability (Gotlieb et al., 1992; Jamil et al., 2023). The degree to which a piece of information influences a consumer's decision-making or not is determined by how reliable SWOM is thought to be. Studies reveal that 82% of consumers deliberately look for bad reviews, and 95% of consumers read reviews before making a purchase. When making purchases online, customers consider the credibility of reviews (Izogo et al., 2023). Hypotheses (H8) state that credibility has not a significant moderate influence on opinion leaders and consumer decision making with the effect size ( $\beta = -0.342$ )<sup>2</sup>. The current results have been validated with the results of previous studies. In the framework of high-involvement purchases, media exposure, social interaction, and product knowledge shapes the power of opinion leaders more so than their reputation alone. These qualities are very important in influencing customer choices apart from the reputation of the opinion leader (Baziyad et al., 2024; Khan et al., 2022). The current research introduces the concept in the first part of examining the function of opinion leadership in influencing the credibility of influencers and consumer decision making. The aforementioned research clearly indicates that the function of opinion leaders is crucial in shaping the image of a product and influencing consumers to make a final purchasing choice.

### **Theoretical Implications**



The goal of the study was to find out how social media influencers influences people in consumer buying decisions by supporting the decision making theory. Given how frequently consumers come across influencer marketing in their daily life, we can call it a very successful and popular form of promotion. However, regardless of the extensive use of this method can still provide a competitive advantage and disadvantages both. Our research has shown that a large part of consumers think that influencers agree to promote a product simply because they get paid for it. People in our analysis uttered the view that only an eye-catching or successful personality is not enough, and the success of the product is mainly up to them. For an effective marketing drive, a combination of these two factors is therefore important: a quality product and a trusted influencer. As an influencer can induce positive emotions and inspire consumers to buy, it can also have the reverse effect. It is relatively common for some personalities to form negative advertising over time, and the public does not receive them with zest. The major risk of influencer marketing is the association of a company with a personality who is tangled in an outrage or causes too many negative reactions.

### **Practical Implications**

There are several practical implications. Firstly, it should be remembered that not only the brand can be negatively influenced by personality, but the promotion of an inappropriate product can harm the influencer himself. Our survey was also attended by respondents who changed their mind about a popular person so far just because they promoted an inappropriate product.(Zak & Hasprova, 2020). Secondly, the credibility and popularity of a social media influencer is therefore declining, and any other project on which it will collaborate may be at risk as it will be supposed by the consumers as unreliable.(Zak & Hasprova, 2020). Thirdly, at a present time, the accessibility and transparency of information provided by social media influencers has intensely influenced the consumer's decision making process; thus, it is important to examine what are the obstacles and hurdles that hold predictions becoming consumers, or keeps consumers hesitant from purchasing again. (Khatib, 2016; Zaheer et al., 2023)Fourthly, consumers are extremely choosy in attending, process, and selecting the information before a purchase takes place. Information exposure is highly selective in the early stage of information, because consumers have the selections of information source, in which determinates the type of data that consumer will be exposed to(Jamil et al., 2024; Khatib, 2016). Lastly, these findings direct for futures



studies to examine the impact of features, such as digital attractiveness, digital expertise, digital interaction and opinion leadership. The influence of social media that might affect consumers' purchasing decision making process. With the rise of Social Media in recent times, the outdated purchasing decision making process of consumers has been modified. Influencers that have always been a source of influence on consumers are playing today an even greater role of guidance through their recommendations on Social Media. (Khatib, 2016)

### **Conclusion**

As we all are aware that at a present time, it has been very common that some people use social media platforms to promote any product or brand by aiming to influence and encourage consumers to buy them, these kinds of people are known as social media influencers. We can easily observe several types of advertising and marketing campaigns in our daily lives while using Instagram, Facebook, and Twitter and so on. These campaigns mainly promote clothes, shoes, beauty or organic products and etc. This kind of influencer marketing is no doubt highly moderate and more beneficial version of advertising, it helps to create a positive image of the respective product or brand in consumers mind which is very important factor in making of the purchase decision. But on another side, creating a positive image is not the only factor that influence consumers, they also focus the point that which influencing personality is doing the advertising campaign, whether that personality is trustworthy or not, whether they are or had been ever involved in any kind of scandals or false marketing or allegations etc. This whole study helped in answering the questions related to every aspect of social media influencers and marketing, their pros and cons, do and don'ts, advantages and disadvantages, or benefits and risks also. Lastly, it taught the strategies and tactics to be applied to encourage consumers in making a purchase decisions. (Zak & Hasprova, 2020)

### **Limitations and Future Direction**

Despite discussing the topic in so much detail but still the study is not free from limitations. Firstly, there are very few variables which are discussed in study, future studies can consider more variables on which the topic will depend. The topic can be discussed in many aspects will make it a broad topic. Secondly, this study focused more on positive sides, future studies has an opportunity to discuss and focus more on negative sides. For example, they can include Negative EWOM (Electronic Word of Mouth), past practices of influencers, an influencer's commercial



orientation and many other. Thirdly, the study considers only credibility as a moderator but there are many possible moderators which can be discussed. Future researches could, thus study the effect of trustworthiness on the relationship between brand and social media influencer. Fourthly, an online data-collection method has been implemented to direct this study. It will be appreciated if future studies make use of field experiments and face to face conversations in order to get honest reactions and answers.(Pradhan et al., 2022). Lastly, future studies can discuss how social media influencers are manipulating consumers just for their benefits as they are getting commissions from brands.

### References

- Abbas, Q., Rehman, A., Jamil, S., Khan, A., & Asad, Z. (2023). Examining the Relationship between Fear of COVID-19 and Absenteeism among Frontline Workers in Pakistan. *Pakistan Business Review*, 25(2), 131-145.
- AL-Sous, N. (2022). Antecedents of social media influencers on customer purchase intention: Empirical study in Jordan. *International Journal of Data and Network Science*.
- Almajali, D. (2022). Antecedents of social media influencers on customer purchase intention: Empirical study in Jordan. *International Journal of Data and Network Scienc*.
- Alocer, H. N. (2017). Word of Mouth and Electronic Word of Mouth: Implications for Consumer Behavior. *Frontiers*.
- Alsokkar, A. (2022). Antecedents of social media influencers on customer purchase intention: Empirical study in Jordan. *International Journal of Data and Network Science*.
- Ao, L., & Bansal, R. (2023). mpact of Social Media Influencers on Customer Engagement and Purchase Intention: A Meta-Analysis. *MDPI*.
- Azzahra, A., Afwa, A., & Moniko, M. (2024). The Influence of Influencer Marketing and Online Customer Reviews on Purchase Intention Through the Perceived Value of Cosmetic Products on Tiktok Shop (An Empirical Study on Students in the City of Pekanbaru). *EKOMBIS REVIEW: Jurnal Ilmiah Ekonomi dan Bisnis*, 12(1), 1487–1502-1487–1502.
- Bazyad, H., Kayvanfar, V., & Toloo, M. (2024). A data envelopment analysis model for opinion leaders' identification in social networks. *Computers & Industrial Engineering*, 110010.
- Bhagat, P., & Ahire, S. (2021). A STUDY OF IMPACT OF DIGITALIZATION ON CONSUMER PURCHASING DECISION IN MUMBAI. *International Journal of Education*.
- chai, S., choi, B., & kim, M. (2022). Why do people speak about products online? The role of opinion leadership. *springerlink*.



- Chen, Y., baesecke, C., & Cheng, Y. (2023). When non-CSR-themed social media influencers endorsed corporate CSR initiatives: Effects of public's perceived influencer characteristics and leadership. *Elsevier*.
- Chin, W. W. (2010). How to write up and report PLS analyses. In *Handbook of partial least squares* (pp. 655-690). Springer.
- De Brito, P. Q. (2022). Connecting Digital Channels to Consumers' Purchase Decision-Making Process in Online Stores. *MDPI*.
- Gadermann, A. M., Guhn, M., & Zumbo, B. D. (2012). Estimating ordinal reliability for Likert-type and ordinal item response data: A conceptual, empirical, and practical guide. *Practical Assessment, Research, and Evaluation*, 17(1), 3.
- Gefen, D., & Straub, D. (2005). A practical guide to factorial validity using PLS-Graph: Tutorial and annotated example. *Communications of the Association for Information systems*, 16(1), 5.
- Ghasemaghahi, M., & Hassanein, K. (2013). Consumers' Satisfaction With Online Information Quality: The Moderating Roles Of Consumer Decision-Making Style, Gender And Product involvement. *Association for Information Systems*.
- Gotlieb, J., Schlacter, J., & St.Louis, R. (1992). Consumer decision making; A model of the effects of involvement, source credibility, and location on the size of the price difference required induce consumers to change suppliers. *Psychology and Marketing*, 208.
- Hair, J. F., Hult, G. T. M., Ringle, C. M., Sarstedt, M., & Thiele, K. O. (2017). Mirror, mirror on the wall: a comparative evaluation of composite-based structural equation modeling methods. *Journal of the academy of marketing science*, 45(5), 616-632.
- Hamed, S., Jamil, S., & Rafiq, H. A. (2022). University Branding And Student Satisfaction: The Emerging Landscape of Universities in Pakistan. *Pakistan Journal of Educational Research*, 5(2).
- Hassan, S. H., Mohamed, N., Ahmad, N. H., Halim, H., & Ramayah, T. (2019). CONCEPTUALIZING PERCEIVED INFOLLUTION PROCESSING AND MANAGEMENT AND ITS CONSEQUENCE ON EMPLOYEE WELL-BEING *Future Academy*, 511.
- Henseler, J., Ringle, C. M., & Sarstedt, M. (2015). A new criterion for assessing discriminant validity in variance-based structural equation modeling. *Journal of the academy of marketing science*, 43(1), 115-135.
- Hsiao, S.-H., Wang, Y.-Y., & Lin, T. L. (2024). The impact of low-immersion virtual reality on product sales: Insights from the real estate industry. *Decision Support Systems*, 178, 114131.
- Izogo, E., Jayawardhena, C., & Karjaluoto, H. (2023). Negative eWOM and perceived credibility: a potent mix in consumer relationships. *International journal of retail and distribution management*, 47.



- Jain, L., Katarya, R., & Sachdeva, S. (2023). Opinion leaders for information diffusion using graph neural network in online social networks. *ACM Digital Library* 37.
- Jamil, S., Khan, S., & Qamar, A. (2024). Journey to Efficiency: The Confluence of Tourism and Supply Chain Agility. *KASBIT Business Journal*, 17(1).
- Jamil, S., Zaheer, K., & Seraj, S. S. (2023). ARTIFICIAL INTELLIGENCE IN CUSTOMER ENGAGEMENT: STRIKING A BALANCE BETWEEN RESPONSIVENESS AND ADVOCACY. *GISRAS Journal of Management & Islamic Finance (GJMIF)*, 3(4).
- jegham, S., & Bouzaabia, R. (2022). Fashion influencers on Instagram: Determinants and impact of opinion leadership on female millennial followers. *Wiley*, 16.
- Khan, S., Jamil, S., & Seraj, S. S. (2022). Consumer Buying Behavior Towards Online Shopping: A Sem Analysis of Financial Capability. *Journal of Journalism, Media Science & Creative Arts*, 2(2), 83-104.
- Khan, S., Rashid, A., Rasheed, R., & Amirah, N. (2021). Designing a knowledge-based system (KBS) to study consumer purchase intention: the impact of digital influencers in Pakistan. *Emerald Insight*, 25.
- Khatib, F. (2016). The Impact of Social Media Characteristics on Purchase Decision Empirical Study of Saudi Customers in Aseer Region *International Journal of Business and Social Science*, 10.
- Kim, H., & Park, M. (2023). Virtual influencers' attractiveness effect on purchase intention: A moderated mediation model of the Product–Endorser fit with the brand. *Computers in Human Behavior*.
- Lavuri, R., & Gopi, R. K. (2024). Demystifying the product attribute nexus: illuminating webrooming behavior in emerging fashion industry. *Journal of Product & Brand Management*.
- leong, C., loi, A., & Woon, S. (2021). The influence of social media eWOM information on purchase intention. *PubMedCentral*, 157.
- louro, & Patricia. (2020). Does Instagram and opinion makers influence on the consumer decision making and buying processes in the fashion and beauty industries?
- Marques, D. N. (2022). Connecting Digital Channels to Consumers' Purchase Decision-Making Process in Online Stores. *MDPI*.
- Millwood, A. (2021). Understanding the Consumer Decision Making Process. *yotpo*.
- Pires, P. B. (2022). Connecting Digital Channels to Consumers' Purchase Decision-Making Process in Online Stores. *MDPI*.
- Pires, P. B., Santos, J. D., Brito, P. Q., & Marques, D. N. (2022). Connecting Digital Channels to Consumers' Purchase Decision-Making Process in Online Stores. *Sustainability*, 21.
- Podsakoff, P. M., & Organ, D. W. (1986). Self-reports in organizational research: Problems and prospects. *Journal of management*, 12(4), 531-544.





- Pradhan, D., Kuanr, A., Pahl, S., & Akram, S. (2022). Influencer marketing: When and why gen Z consumers avoid influencers and endorsed brands. *Wiley*, 21.
- Ren, X., Wang, L., & Luo, X. R. (2024). How customized managerial responses influence subsequent consumer ratings: The language style matching perspective. *Decision Support Systems*, 114188.
- sa'ait, N., & Kanyan, A., Nazrin, F. (2016). The Effect of E-WOM on Customer Purchase Intention. *international academic research journal*, 80.
- Saeed, M., & Shafique, I. (2020). Customer-based brand equity and destination visit behaviour in the tourism industry: the contingent role of social media. *Quality & Quantity*, 54(5), 1491-1512.
- Santos, J. D. (2022). Connecting Digital Channels to Consumers' Purchase Decision-Making Process in Online Stores. *MDPI*.
- Schuberth, F., Henseler, J., & Dijkstra, T. K. (2018). Partial least squares path modeling using ordinal categorical indicators. *Quality & Quantity*, 52(1), 9-35.
- Yuan, S., & Lou, C. (2020). How social media influencers foster relationships with followers: The roles of source credibility and fairness in parasocial relationship and product interest. *Journal of Interactive Advertising*, 20(2), 133-147.
- Zaheer, S. A., Anis, U., & Jamil, S. (2023). EXPLORING MASSTIGE MARKETING: A PRACTICAL INVESTIGATION INTO CONSUMER PERCEPTIONS AND PRODUCT ATTRIBUTES. *Journal for Business Education and Management*, 3(2), 35-58.
- Zak, S., & Hasprova, M. (2020). The role of influencers in the consumer decision-making process. *SHS Web of Conferences*, 7.